



GEA TriplexPanda Lab Homogenizer 600

Laboratory Homogenizer Technical datasheet

This small table-top unit, designed for continuous operation at high pressure, is the perfect equipment for laboratory scale high pressure processing of dairy products, fruit juices, liquid food, food additives and ingredients.

Tests can be run even with small sample volumes, and the results can be scaled up on industrial homogenizers.

The machine is suitable for CIP and SIP.

Main options

- Variable capacity (50% - 100%) with frequency converter
- Aseptic execution
- 3-A execution
- FDA approved gaskets and cGMP documentation

Technical data

Number of plungers	3
Net weight	200 kg
Gross weight	246 kg
Dimensions (mm)	W 656 x H 557 x L 853
Minimum sample volume	approx. 750 ml
Noise level	≤70 dB(A) ± 2
Feeding hopper volume	4,5 l

Triplex Panda 600 型

使用圧力 : MAX.600bar (60MPa)
処理量 : 1 l /分 (60 l /時)
動力 : 2.2kw x 3相

同栄商事株式会社

〒555-0025 大阪市西淀川区姫里2丁目17番32号
エールリベルテ2F

TEL:06(4808)8100 FAX:06(4808)8222
E-mail:info@doyei.com
URL:http://www.doyei.com

GEA TriplexPanda Lab Homogenizer 600

Laboratory Homogenizer

Liquid end

- High grade and high performance Super Duplex stainless steel and special high wear resistant material
- Solid ceramic pumping plungers
- Suction and delivery ball valves (PVB) in tungsten carbide, with replaceable suction valve seat in tungsten carbide
- Pressure transmitter with 4-20 mA remote pressure signal

Homogenizing valve

- Manual pressure adjustment by means of a hand-wheel
- Reversible wear parts in tungsten carbide
- Second stage as standard

Power end

- AC motor drive, suitable for variable speed drive
- Camshaft drive system and maintenance-free grease lubrication
- Maintenance-free timing belt drive

Casing

- Panels made in polished stainless steel, completely removable for maintenance and cleaning
- High quality shot peening stainless steel base frame
- Adjustable anti-vibration rubber feet

Safety kit

- Plastic control board fixed inside the machine
- Emergency pushbutton
- Start/stop pushbutton
- Built-in safety protection against overpressure

Product inlet/outlet

- 1/2" Tri-Clamp™
- Tri-Clamp™ connections for inline installation
- No feeding pump is needed (for product viscosity up to 1.000 cP)
- SS feeding hopper (4,5 l) supplied as standard

Dimensional drawing

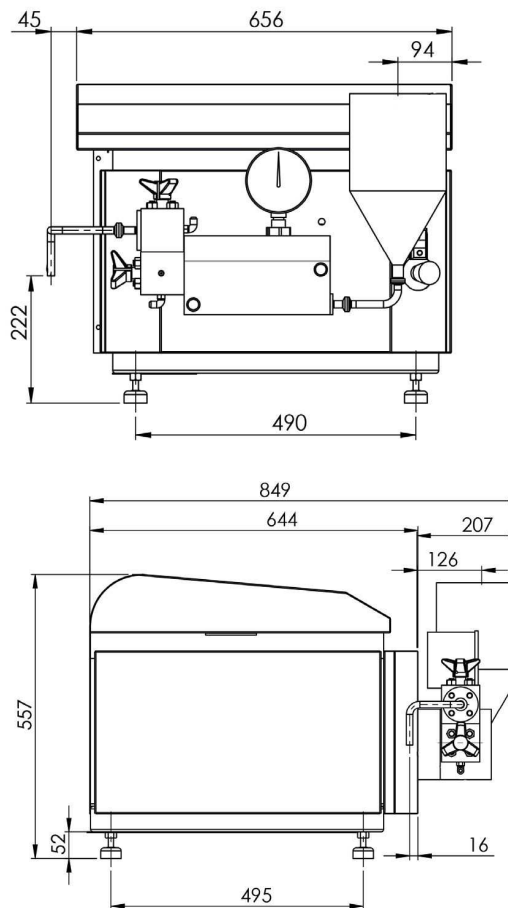

Overall dimensions (mm)

Flow Rate (l/h)	Pressure (bar)	Electrical Supply (Hz)
60	600	50/60

オプション：

- 吐出ラインクーラー
- 高粘度用圧力フィーダー（1000cP以上）
- キャスター付き架台

GEA Italy

GEA Mechanical Equipment Italia S.p.A.

Via A. M. Da Erba Edoari, 29

43123 Parma, Italy

Phone +39 0521 965 411

Fax +39 0521 242 819

gea.com/contact